

Full instructions for making CHILDREN'S HOUR

At five o'clock each evening Children's Hour on B.B.C. Television is announced by a musical roundabout on which are a succession of delightful little figures in various playful poses. This highlight of the children's viewing has been captured permanently by our design for a model T.V. Roundabout in which we have had whole-hearted co-operation from Miss Dorothy Rogers of Hampstead, N.W.3, who designed the original figures.

These figures in their delightful colourings rotate in their correct sequence and positioning on a baseboard, activated by a movement which is also responsible for the music. Children will love watching these figures cavorting to the merry music, and their cutting out and colouring will give fretworkers a chance to show their skill.

Not difficult

There is nothing difficult about the makeup of this charming model, but it will be appreciated that clean cutting and a good finish will go a long way towards ensuring a novelty that will be the envy of all who see it.

In one respect we have not been able to make this model quite authentic. The action is anti-clockwise due to the nature of the mechanism. But the Moon Knight and Sun Knight still proudly bear their banners, the Kitten plays happily with a ball, the Little Boy topples, the Little Girl, the Ballerina and Sailor are seen in their various dances — in fact, all are there as seen on T.V. No father can surely resist making this up for his child.

On the design sheet, each figure excepting the small trees, is shown in detail — back and front — as a guide to painting, a colour key also is given. Each figure is provided with a tenon which fits into a mortise on the baseboard.

Cutting the figures

There are two ways of cutting out the figures. They can be traced and marked out on to the wood and cut out with a fretsaw. Then on the back of each figure trace the appropriate marking for painting. After cleaning up with glass-paper, the figures are now ready for painting with enamel as detailed on the key.

A second way is to cut out the patterns of the figures (front view) from the design sheet, paste these on to wood and cut out with the fretsaw. Then cut out the reverse markings from the design sheet and paste them to the backs of the figures. This method will enable poster

Get your Kit now — only 5/-

THERE is bound to be a great demand for kits to make up the Television Roundabout and readers are urged to send for theirs right away. Kit No. 3179 contains all the materials needed and costs only 5/-. It is obtainable from Hobbies branches, etc., or post free from Hobbies Limited, Dereham, Norfolk.

Similarly there are several musical movements available for incorporating into these models. Costing 18/11, the tunes are listed below. When ordering by post please give 1st, 2nd and 3rd choice of tune in case your selection is out of stock.

Auld Lang Syne
Home Sweet Home
Blue Bells of Scotland
Bells of St. Mary's
Brahm's Lullaby
Harry Lime Theme
Some Enchanted Evening
Moulin Rouge
Limelight
Merry Widow

Blue Danube
Vienna, City of my Dreams
Swedish Rhapsody
Irish Eyes are Smiling
Greensleeves
Parade of the Wooden Soldiers
Silent Night
O My Papa
Jingle Bells
Always

paints to be used, which give an advantage of quick drying, but, of course, enamel can also be used, and will possibly give better results as regards durability and shine.

The top of the pole on which the cuckoo clock will be glued can be cut away with a knife to give a flat surface for about 1 in. of its length. The winding weights of the clock and the pendulum are fixed by means of pieces of thread and a length of thin wire, as is clearly shown on the design sheet.

With the figures all prepared, the next stage is to cut out the circular baseboard (18) from $\frac{1}{4}$ in. wood, making it 7 ins. diameter (Fig. 1). In the centre, a hole and slot must be cut, so that the winder key fits into this tightly. This must be a pressed fit in order to ensure rigidity of assembly.

The positions of the figures as they appear on the baseboard are seen in Fig. 1, and the mortises in the baseboard can be marked from the tenons on the figures. When these mortises have been

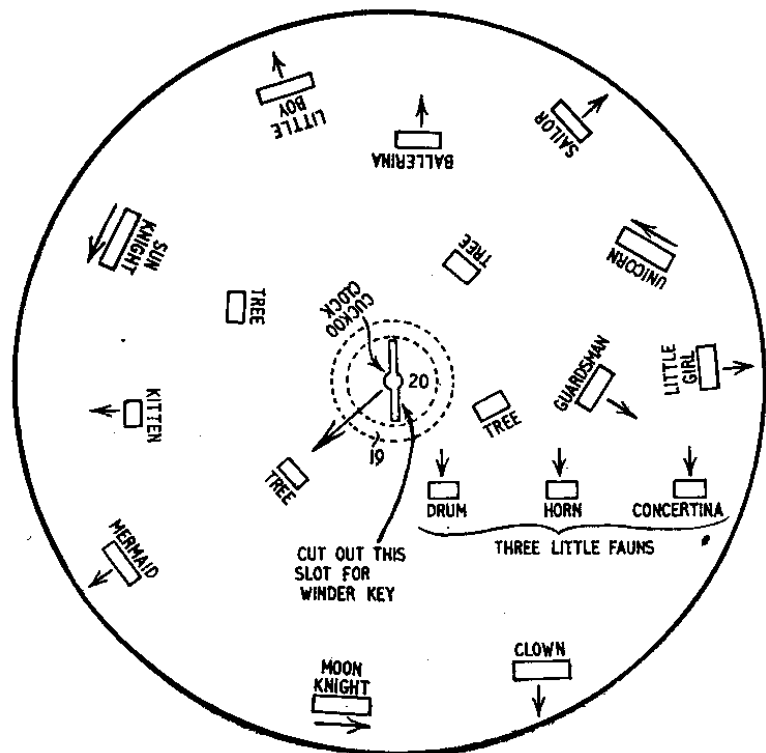

Fig. 1

T.V. ROUNDABOUT

cut out, clean up the baseboard and paint both sides. It is suggested that pale blue, cream or white enamel will accentuate the outlines of the figures. Paint a black scallop around the edge of the baseboard as seen in the photographs.

The box in which the musical movement is contained is made up from five pieces of wood (Fig. 2). The four sides (22 and 23) are of $\frac{1}{4}$ in. thick wood, and the top (21) is $\frac{1}{2}$ in. thick. Pin and glue these together. The hole for the winder spindle must be in the centre of piece 21, and this centre is determined by drawing diagonals (Fig. 2).

Fixing the movement

Next screw the musical movement inside the box (Fig. 3) in any convenient position, with winder spindle projecting through the hole, but ensuring that the stopper arm of the movement is free (i.e. — not touching the sides of the box). If the screws extend beyond the top of the box, the ends should be filed off so as not to foul the underside of the baseboard. This box assembly can now be cleaned up, and the sides painted to the desired colour which should, preferably, be a matching one to that of the baseboard.

All is now ready to glue the figures into their appropriate positions on the baseboard. Use balsa cement, as this is colourless. The staffs carrying the banners worded 'Children's Television' consist of portions of No. 13 knitting needles. Before gluing the knights carrying these banners into position, holes should be provided in the base-

board to take the needles. Extra support for the needles can be obtained by a dab of cement on the back of the knights. Ensure that the figures are facing the correct way by studying the arrows in Fig. 1

The banners are shown full size on the design sheet, and the wording should be painted on both sides. Glue these banners in their trailing positions as indicated by the photograph of the finished roundabout.

Next screw the winder key of the musical movement on to its spindle, and holding the movement with one hand, press the baseboard down on to the key, so that the key fits tightly into the slot provided. Wind up the movement by holding the box in the left hand and pulling the baseboard towards you, with the right hand gripping the edge of the baseboard (Fig. 4). Allow the movement to unwind and while it is doing so, adjust the rotating baseboard so that it

runs true in a perfectly horizontal movement. To seal this position, fill up the key slot with stiff glue and allow it to dry for twenty-four hours. Glue can be stiffened by allowing it to become exposed to the air for a short time, and this will ensure that none runs through the slot.

Colour plan for figures on page 19

The cuckoo clock is the final piece to be added to the roundabout. The pole for this is glued into pieces 19 and 20, and this assembly is then glued in turn over the top of the winder key (Fig. 1).

One final word of warning. Gentle handling when winding the movement is called for in order not to upset the true running of the baseboard, and take care not to damage the figures.

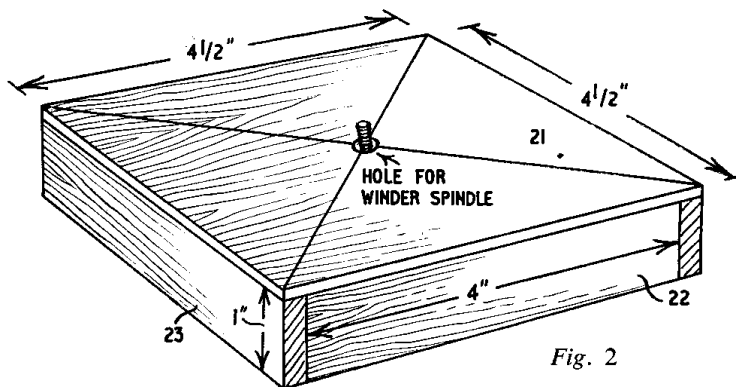

Fig. 2

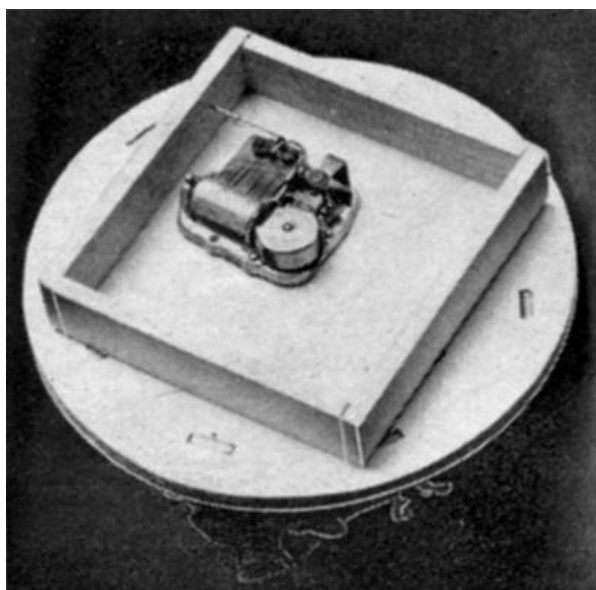

Fig. 3

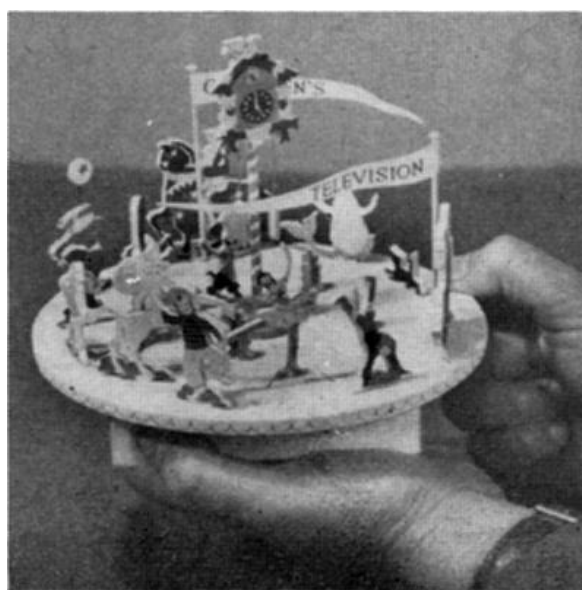

Fig. 4

KEY FOR COLOURING T.V. ROUNABOUT

Only the merest dots for eyes and mouths are possible on these small faces and do not try to add too much detail to the features.

MOON KNIGHT —	Silver armour, collar and helmet Royal blue surcoat with silver moons Cornflower blue plume Black horse Royal blue pall, silver moons and stars points Cornflower blue bridle and harness, with silver stars and bosses Cornflower blue stirrups Silver saddle	SAILOR —	Red hair and whiskers Royal blue jersey, pale blue stripes Straw hat, dark blue ribbons White trousers Bare feet
SUN KNIGHT —	Gold armour, collar and helmet Flame coloured surcoat with gold suns Orange plume White horse Flame coloured pall, gold suns and points Orange bridle and harness, gold sun-bosses Orange stirrups Gold saddle	LITTLE FAUNS —	Flesh colour (buff, not pink) Reddish brown hair on heads and legs Green leaves round necks Horns drawn with pencil White instruments with gold mounts Flesh coloured hooves
UNICORN —	White: pale grey outlines where necessary Silver and white horn Pale pink nose and hooves Rose pink flowers, green leaves	MERMAID —	Very pale blonde hair Seaweed necklace and long ends, red coral Pale green tail and fins with dark green spots
KITTEN —	Black, with white cap, shirt front and tail tip Pink ball	CUCKOO CLOCK —	Clock medium grey with dark grey border, silver grey leaves, flowers and bird Silver grey weights, and leaf on pendulum Dark grey face, white figures and hands Copper and white striped column
TREE —	Half dark, half light green Wood coloured base	LITTLE BOY —	Fair hair Royal blue lumber jacket Grey shorts and socks Tan shoes
LITTLE GIRL —	Fair hair Turquoise blue dress with white spots White collar White socks Black shoes	GUARDSMAN —	Black bushy, gold chinstrap Scarlet tunic, white piping down front Gold buttons, white belt, gold buckle Dark blue cuffs, white piping Dark blue trousers and collar Black boots Brown rifle Silver bayonet
BALLERINA —	Dark hair Silver crown White dress with silver spots Silver leaves on bodice Bright sugar pink tights, pale pink shoes	CLOWN —	White ball, red stars on bright green pole White face, black crosses for eyes Red nose, mouth, ear Orange hair with very wide parting Crimson coat, trousers, white shirt and big collar Green tie and buttons, green shoes

GENUINE Swiss Musical Movements. The best and largest selection of tunes in the country, lowest prices 16/3 each. Genuine Thorens Movements, 22/9 each. All guaranteed. P & P. 9d. extra on all orders. — Richardson & Forder, HW, 5 Chapel Place, White Hart Lane, London, N.17.

SWISS MUSICAL MOVEMENTS. Before you buy send 2d. stamp for our illustrated brochure. — Metwood Accessories (Dept. HW), Church St., Wolverton, Bucks. (Trade enquiries invited).

CONJURING catalogue and Trick Changing Card. 1/-. — DeHempsey, 363 Sandycombe, Kew, Surrey.

MODEL RAILWAY MAGIC. The beginner's book 2/6. 'Making a baseboard' 6d. Bargain list 4d. — Southgate Hobby Shop, 1 The Broadway London, N.14.

MODERNISE YOUR HOME WITH ARNOBOARD

Send 1/6 for R. W. D. Kirkham's comprehensive illustrated book which shows you how; and FREE SAMPLE of Arnoboard, the prefinished plastic surfaced hardboard which works like ordinary hardboard. Finishes include wood grain, tile, marble effects, etc.

Dept. 3, Arnolite Ltd, West Parade, Spring Bank, HULL

'PAINTSPRAYING' HANDBOOK. Covers Car, Industrial & Flock Spraying. 3/6, post 4d. Catalogue of our Cellulose and Paints and all Allied Sundries 24d. — Leonard Brooks Ltd., 81 Oak Road, Harold Wood, Essex.

FREE Stamp Album and 20 stamps. Request approvals enclosing 4d. Additional gifts given. — Beeze, 8 Langland Villas, Mumbles, Swansea.

WANTED old pistols and revolvers. Particularly those marked 'Colt'. — Todhunter, 34 Sutton Court, Chiswick, London.

PLYWOOD; large sizes, 14 lbs. 10/- delivered (Express). C.W.O. — H. Leader (1920), Gosford St., Middlesbrough.

LEARN it as you do it — we provide practical equipment combined with instruction in Radio, Television, Electricity, Mechanics, Chemistry, Photography, etc. — Write for full details to E.M.I. Institutes, Dept. HW47, London, W.4.

100 DIFFERENT stamps free! Request 4d upwards discount approvals. — Bush, 53 Newlyn Way, Parkstone, Dorset.

STAMPS FREE — Empire Packet including SPictorials and Victorians with approvals. — Robert J. Peck, 7A Kemp Road, Bournemouth.

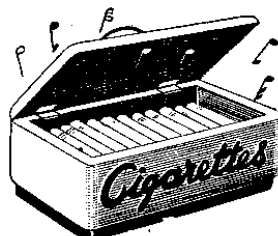

Musical Cigarette Box
It plays when you lift the lid. Full kit to make 4/10 musical movements to fit, 18/10 (ask for tune titles available).

Hobbies have hundreds of designs and kits from which, with a few simple tools, it is easy to make toys, colourful galleons, musical novelties like those illustrated, lovely models, and a host of other delightful things.

Get Hobbies 1957 Handbook (2/- from news-agents, etc., or by post 2/3) and this will show you how to *really* enjoy your hobby.

To Hobbies Ltd, 991, Dereham, Norfolk.
Please send free 20-page booklet and items market thus: X

- Musical Cigarette Box, Kit No. 3106 - 4/10
 List of musical movements available at 18/10
 Hobbies 1957 Handbook, 2/3 post free.

Name.....
Address.....
.....